

## POLE SPECIFICATIONS

### Description:

- A1** Spigot Diameter : Ø76
- A2** Base Diameter : Ø114
- B** Wall thickness [mm] : 3
- C** Access door [mm] : 90x250
- D** Opening position [mm] : 800

\*Pole material: Aluminium

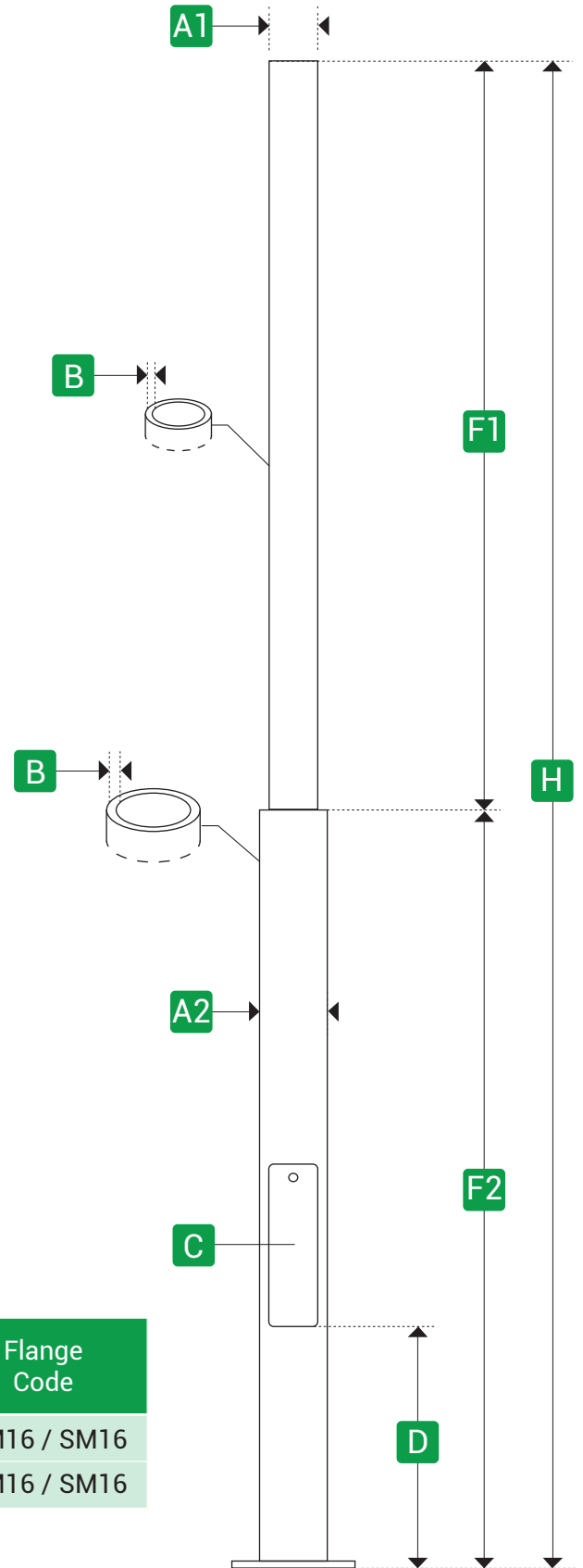

<b>H</b> Height [m]*	<b>F1</b> Top Height [m]	<b>F2</b> Base Height [m]	Weight* [kg]	Flange Code
5	4	1	-	CM16 / SM16
6	4	2	-	CM16 / SM16

\* Total weight of unpainted pole with the given flange (CMXX) without additional accessories.



## FLANGE & ANCHORAGE SPECIFICATIONS

**CM16**

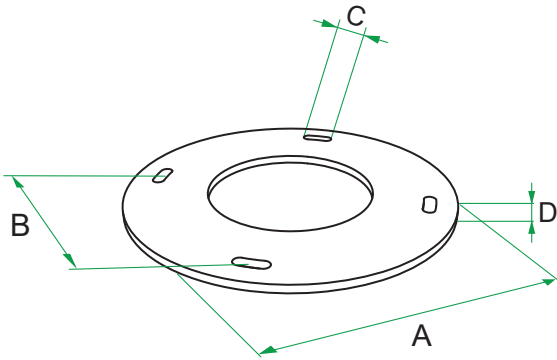

**SM16**

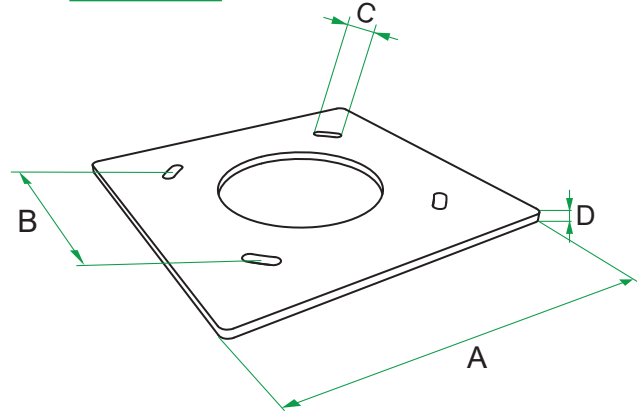

Pole Height [m]	FLANGE DIMENSIONS [mm]					
	Anchorage Code	Flange Code	A	B	C	D
5	A16	CM16 / SM16	350	208 / 257	47	15
6	A16	CM16 / SM16	350	208 / 257	47	15

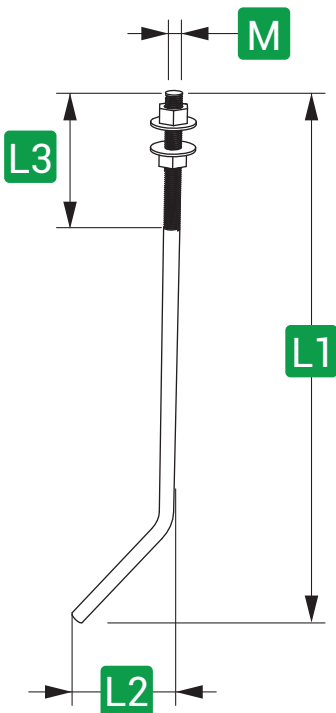

Anchorage Code	J-BOLT DIMENSIONS [mm]			
	M	L1	L2	L3
A16	M16	500	90	100



## ANCHORAGE

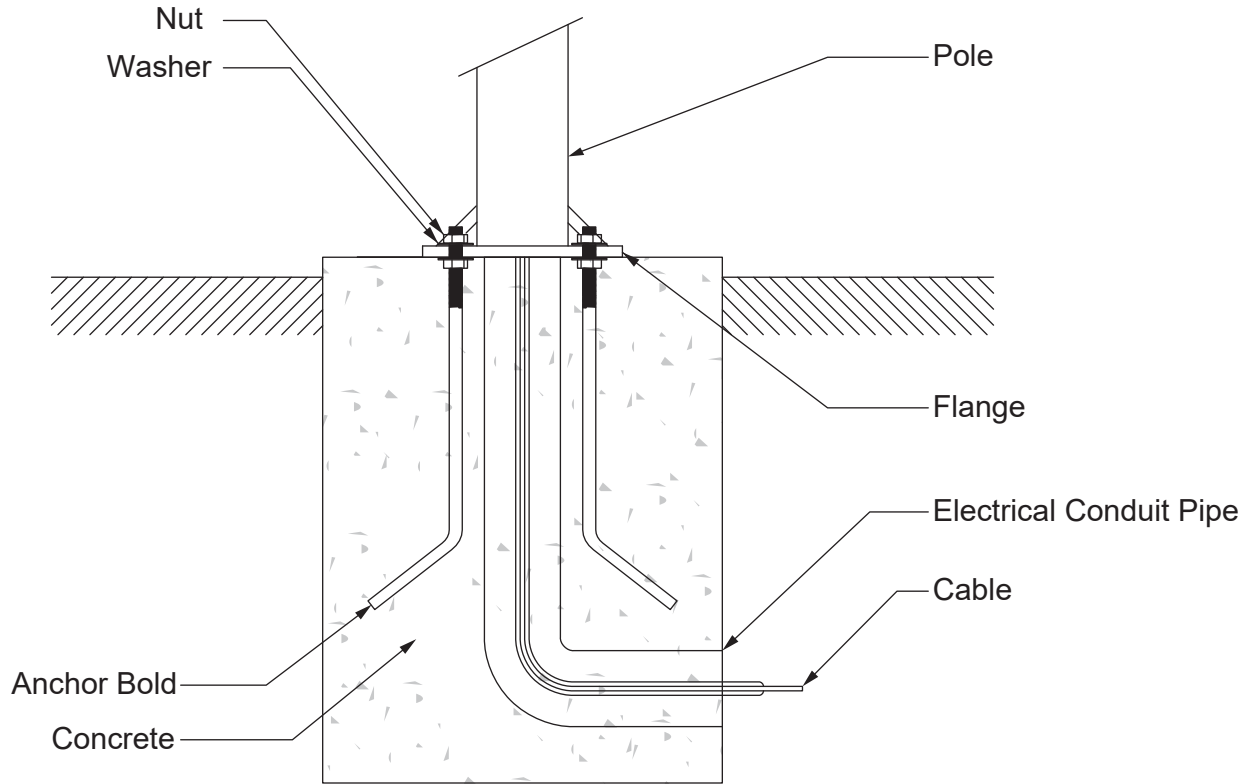

### Light Poles:

The primary function is to resist the physical forces of luminaire weight, ice and wind loads that light poles may encounter during their expected design life. Along with the foundation system, the primary force a pole must withstand is from wind. Because of the variety of pole shapes and heights as well as the size and quantity of luminaires to be supported, including other items that may be attached to the pole, an engineering analysis must be done to ensure the customer will receive a pole adequate for the task.

The light pole must be capable of providing a long service life, require little maintenance and be aesthetically pleasing. Due to the possibility of unforeseen loadings and wind events, the light pole should also have an ample margin of structural capacity.

### FLANGE TYPES

