

POLE SPECIFICATIONS

Description:

- A** Diameter : Ø76
- B** Wall thickness [mm] : 3
- C** Access door [mm] : 55x220
- D** Opening position [mm] : 800

*Pole material: Stainless steel

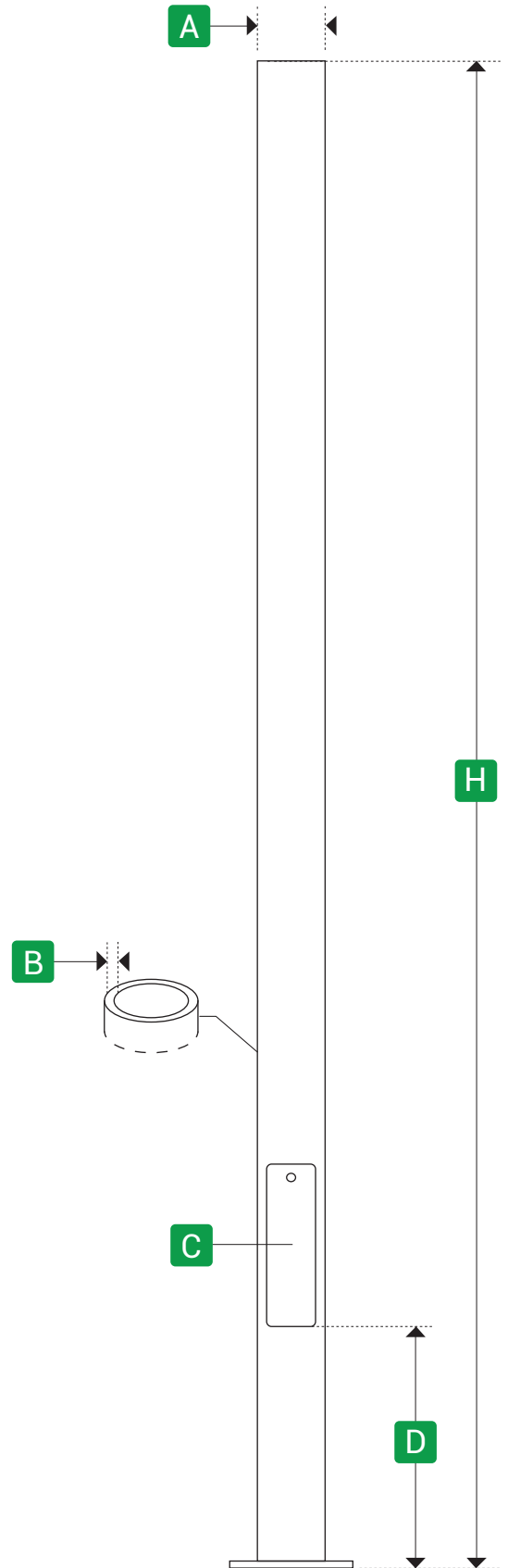

H Pole Height [m]*	Weight* [kg]	Flange Code
3	-	CM12 / SM12
4	-	CM12 / SM12

* Total weight of unpainted pole with the given flange (CMXX) without additional accessories.



FLANGE & ANCHORAGE SPECIFICATIONS

CM12

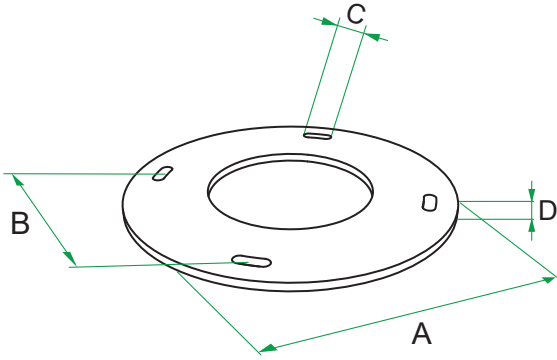

SM12

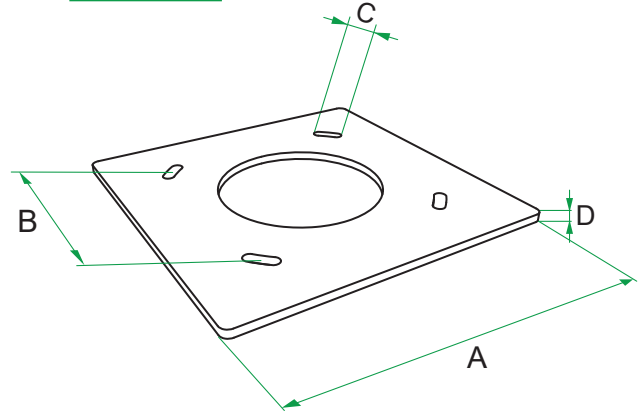

Pole Height [m]	FLANGE DIMENSIONS [mm]					
	Anchorage Code	Flange Code	A	B	C	D
3	A12	CM12 / SM12	250	208 / 257	43	10
4	A12	CM12 / SM12	250	208 / 257	43	10

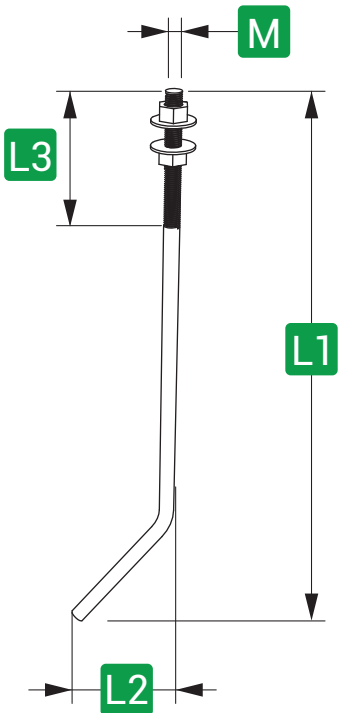

Anchorage Code	J-BOLT DIMENSIONS [mm]			
	M	L1	L2	L3
A12	M12	350	50	100



ANCHORAGE

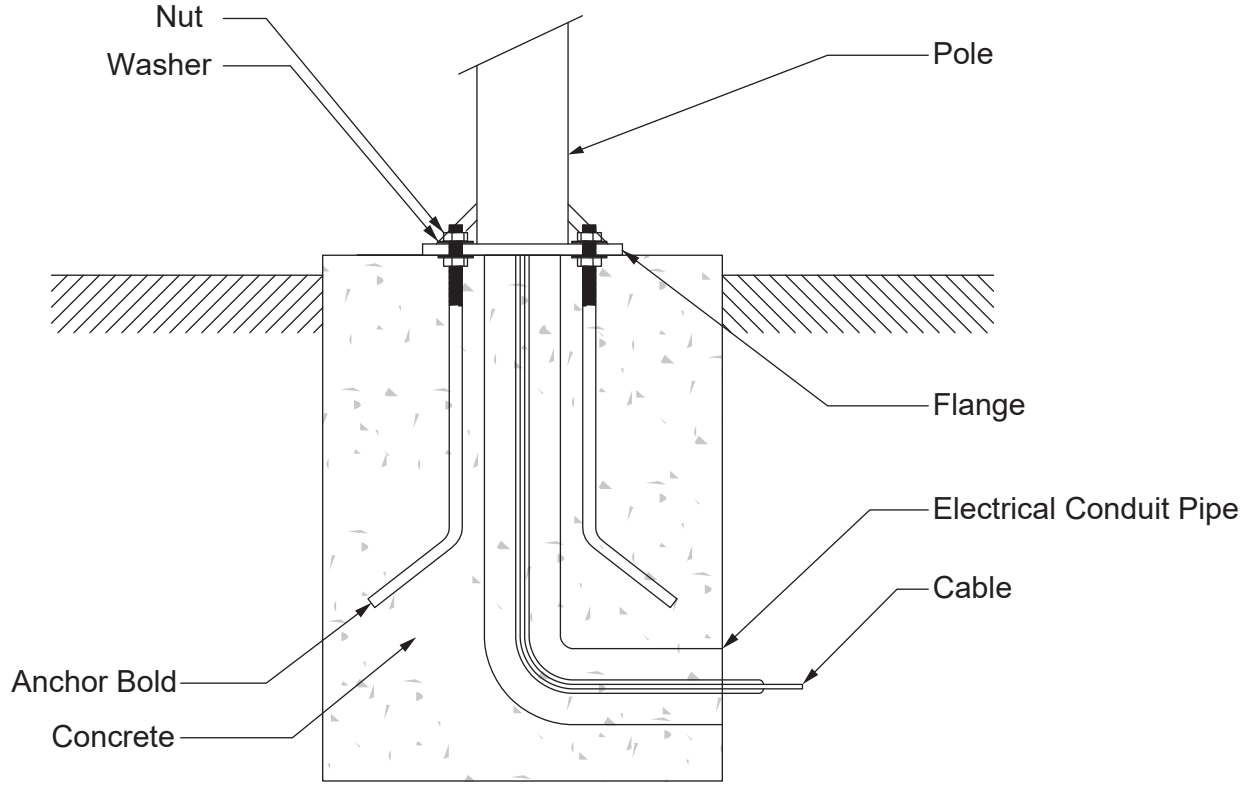

Light Poles:

The primary function is to resist the physical forces of luminaire weight, ice and wind loads that light poles may encounter during their expected design life. Along with the foundation system, the primary force a pole must withstand is from wind. Because of the variety of pole shapes and heights as well as the size and quantity of luminaires to be supported, including other items that may be attached to the pole, an engineering analysis must be done to ensure the customer will receive a pole adequate for the task.

The light pole must be capable of providing a long service life, require little maintenance and be aesthetically pleasing. Due to the possibility of unforeseen loadings and wind events, the light pole should also have an ample margin of structural capacity.

FLANGE TYPES

